

Jasmyn Lopuszansky

Womenswear Designer

Contact
07570798551
Jazzyb10@hotmail.co.uk

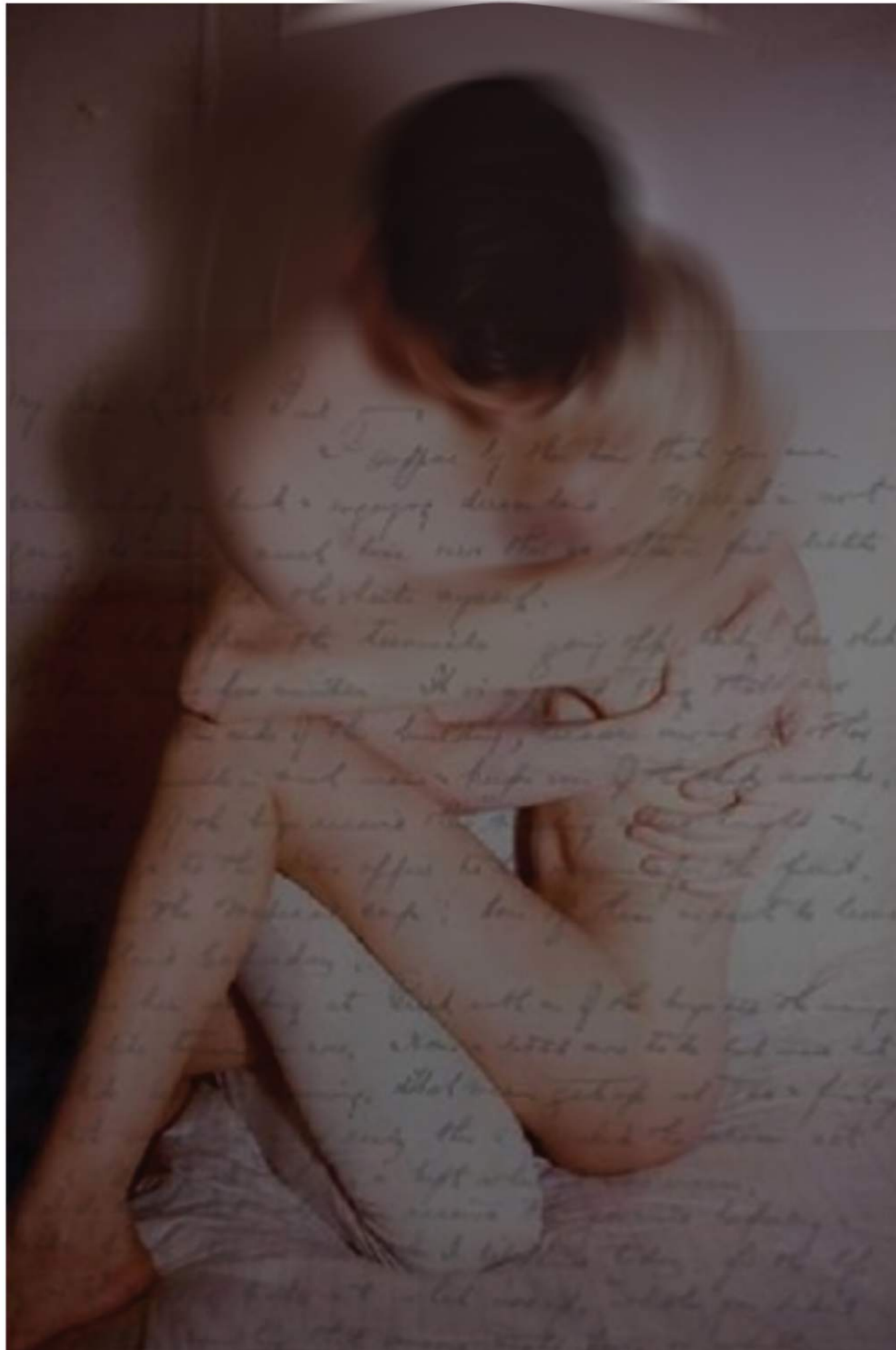

LAYERS OF TRUST

In my collection I aim to create a total of 4 full looks, each look will show a symbolic depiction of the physical, mental, and emotional stages of a new relationship after being heart broken. This will be expressed through garment structure and will represent a positive metamorphosis occurrence. My theme is based on a woman who was once broken hearted, lost her self-value and learns to love again. Each look will represent her progression, implying to not hide herself and her body but instead trust that she can take risks, find beauty within, be happy and fall in love.

My selected target audience is youthful and elegant women, that have a sense of self-worth and sophistication. The focus is on luxury and high class ready to wear, but that is light.



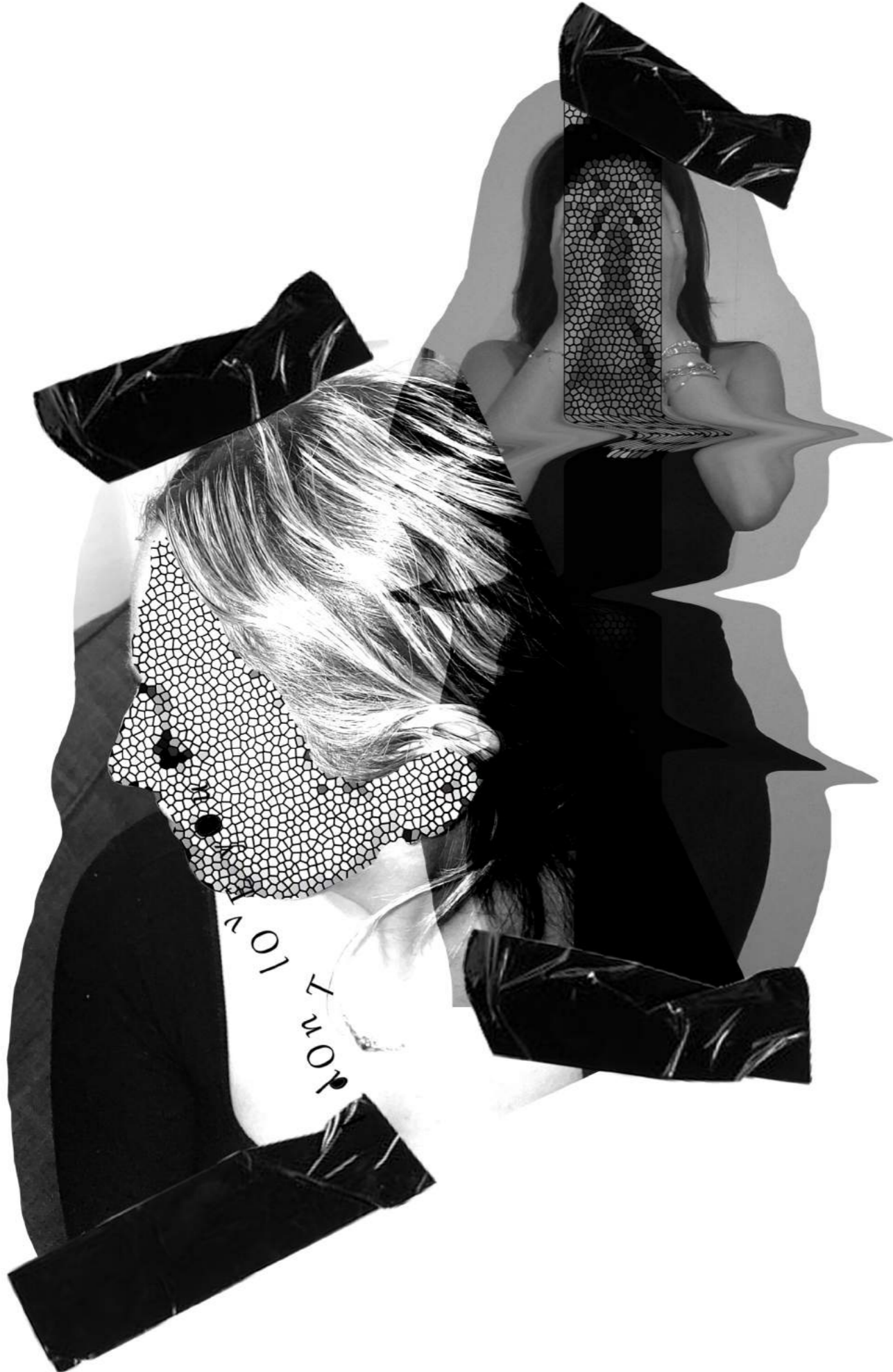

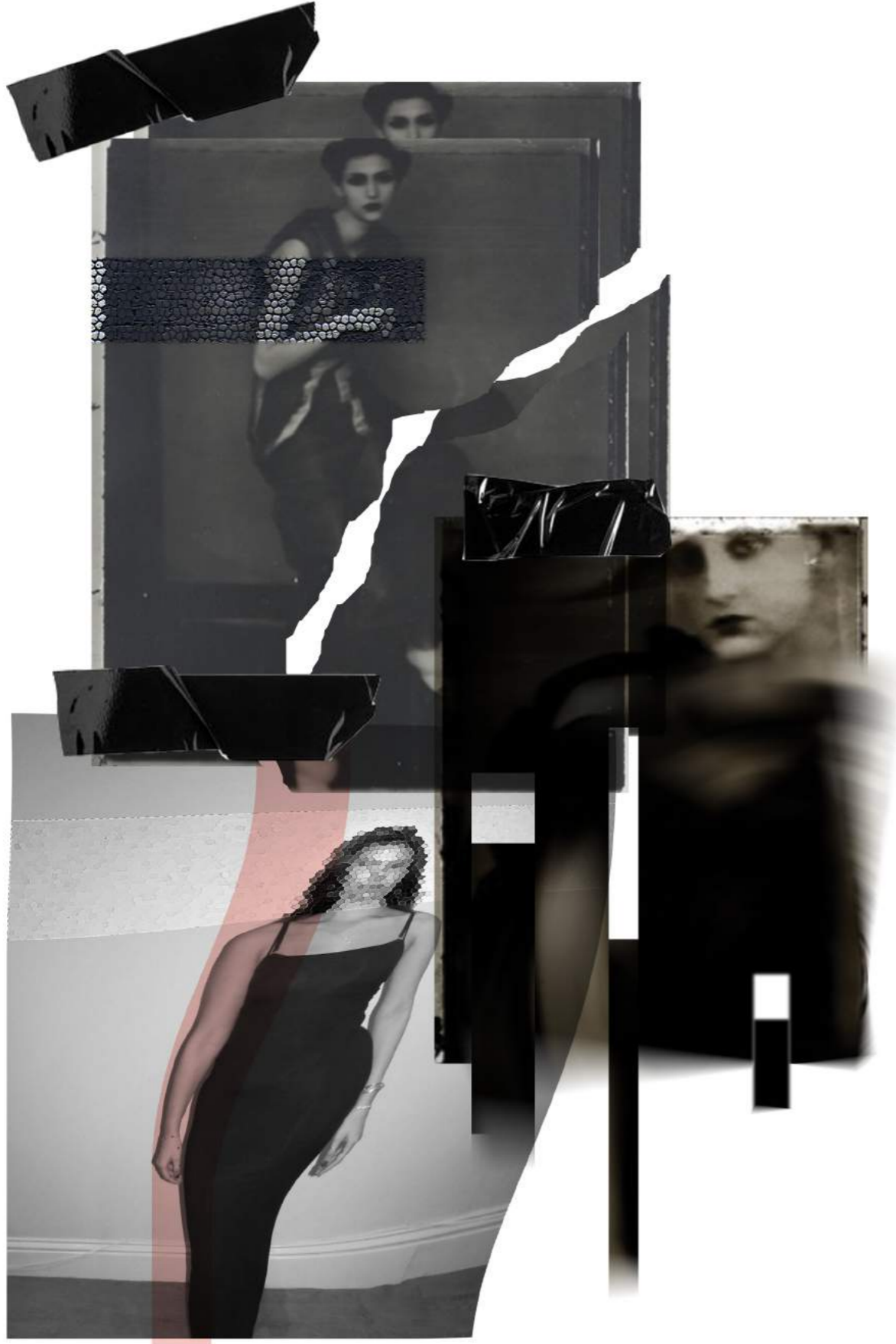

I Feel Like I'm Not Enough

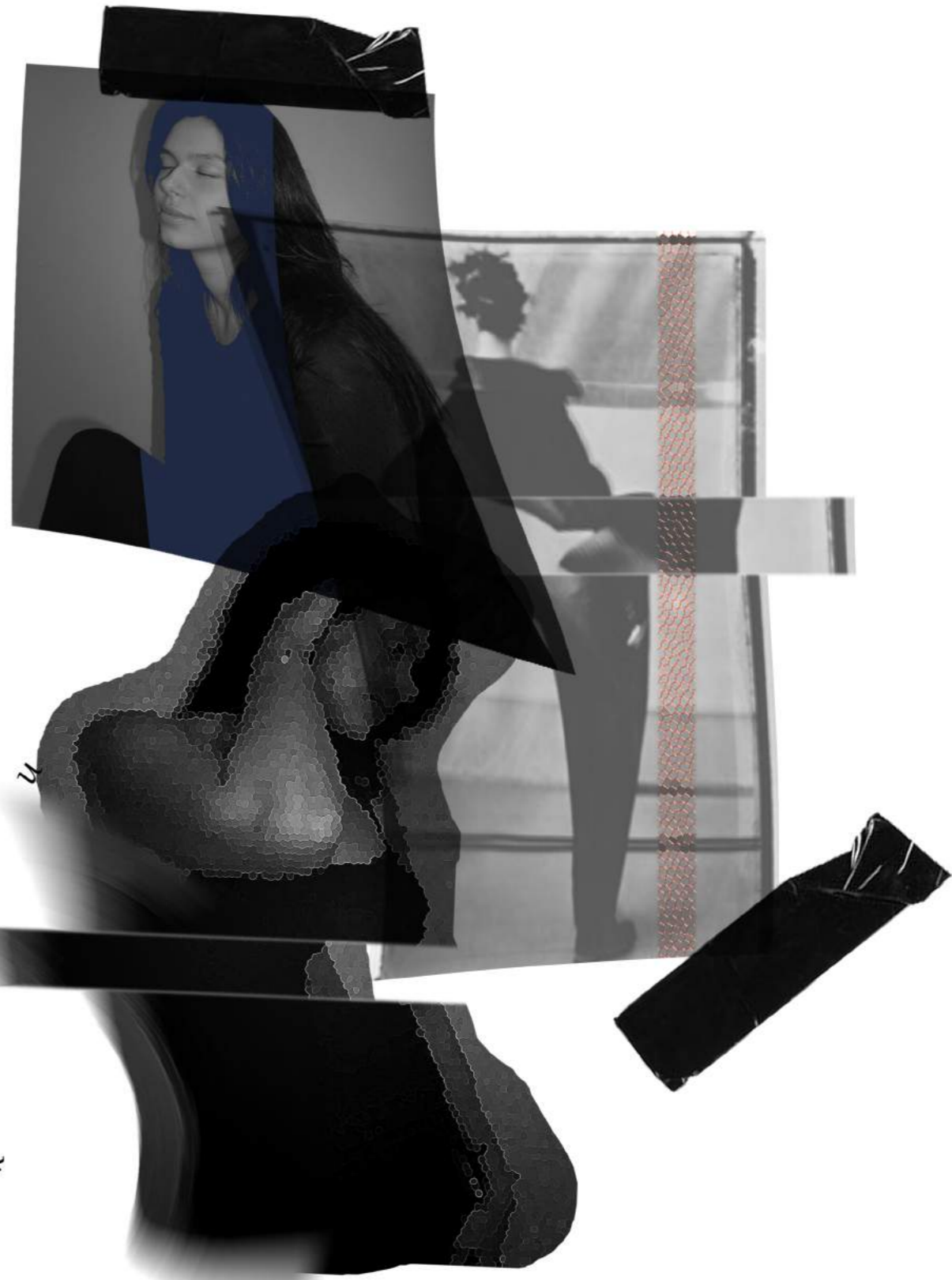

I will NEVER leave you

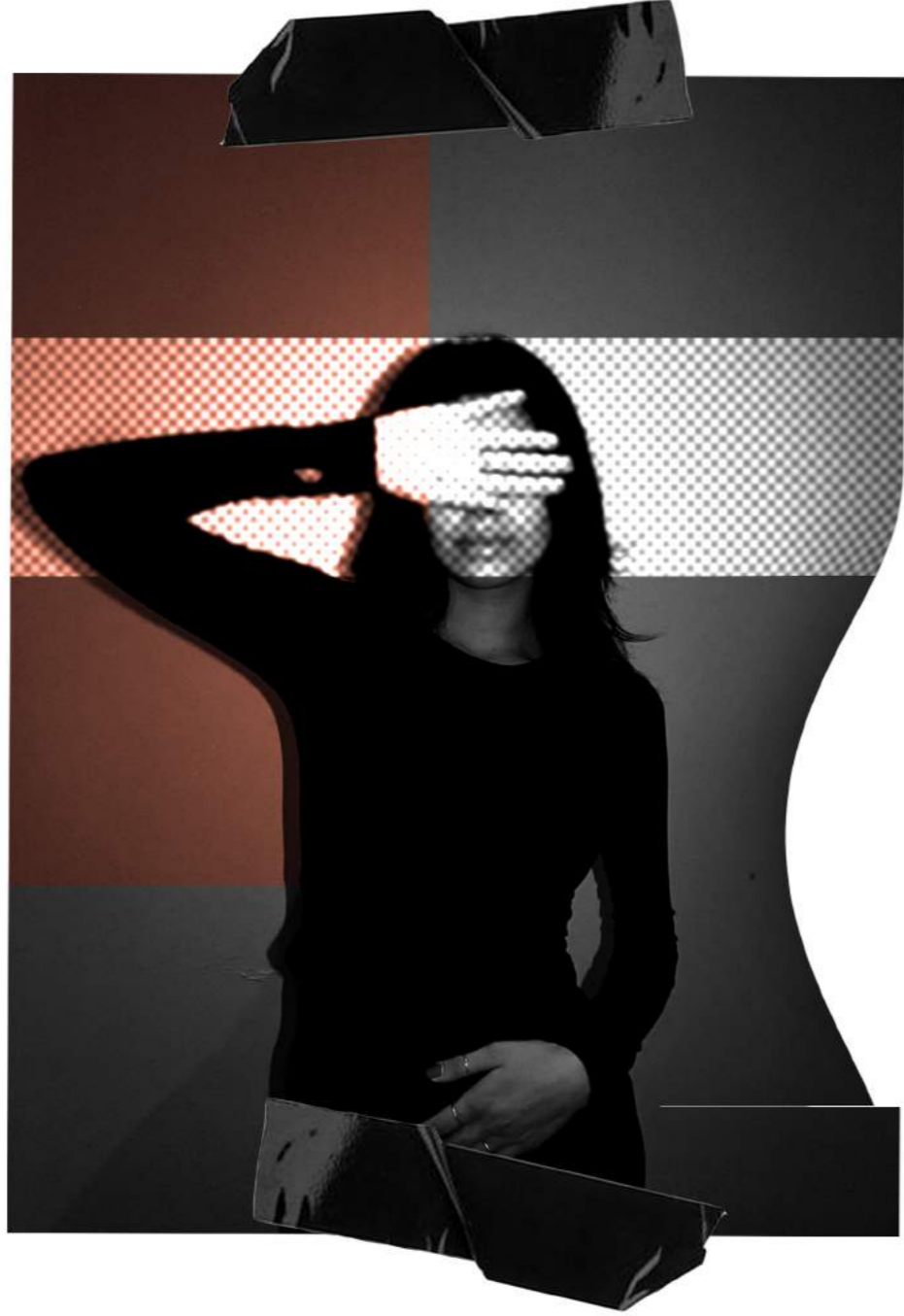

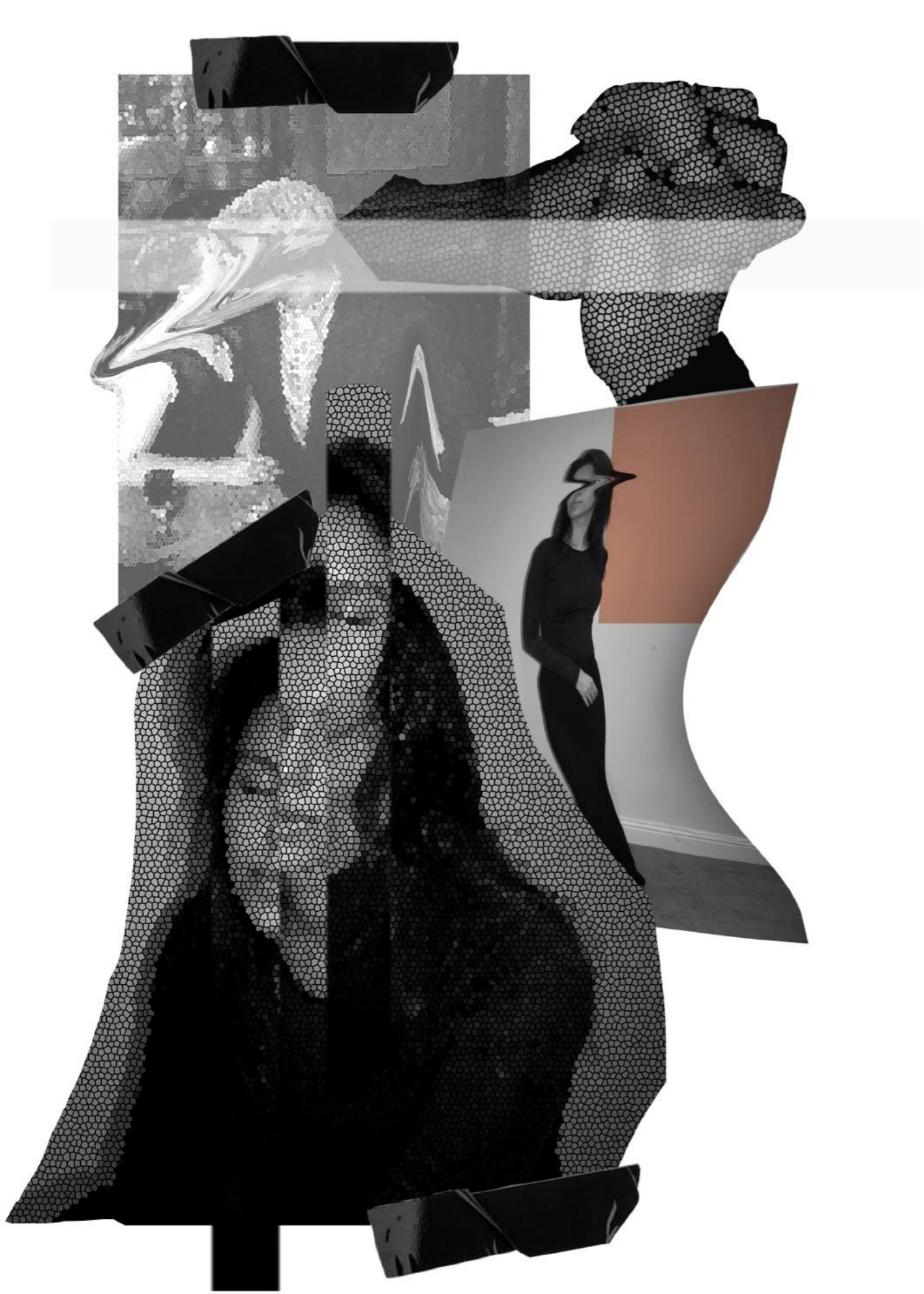





Y • U' R s o b a u t i f u l





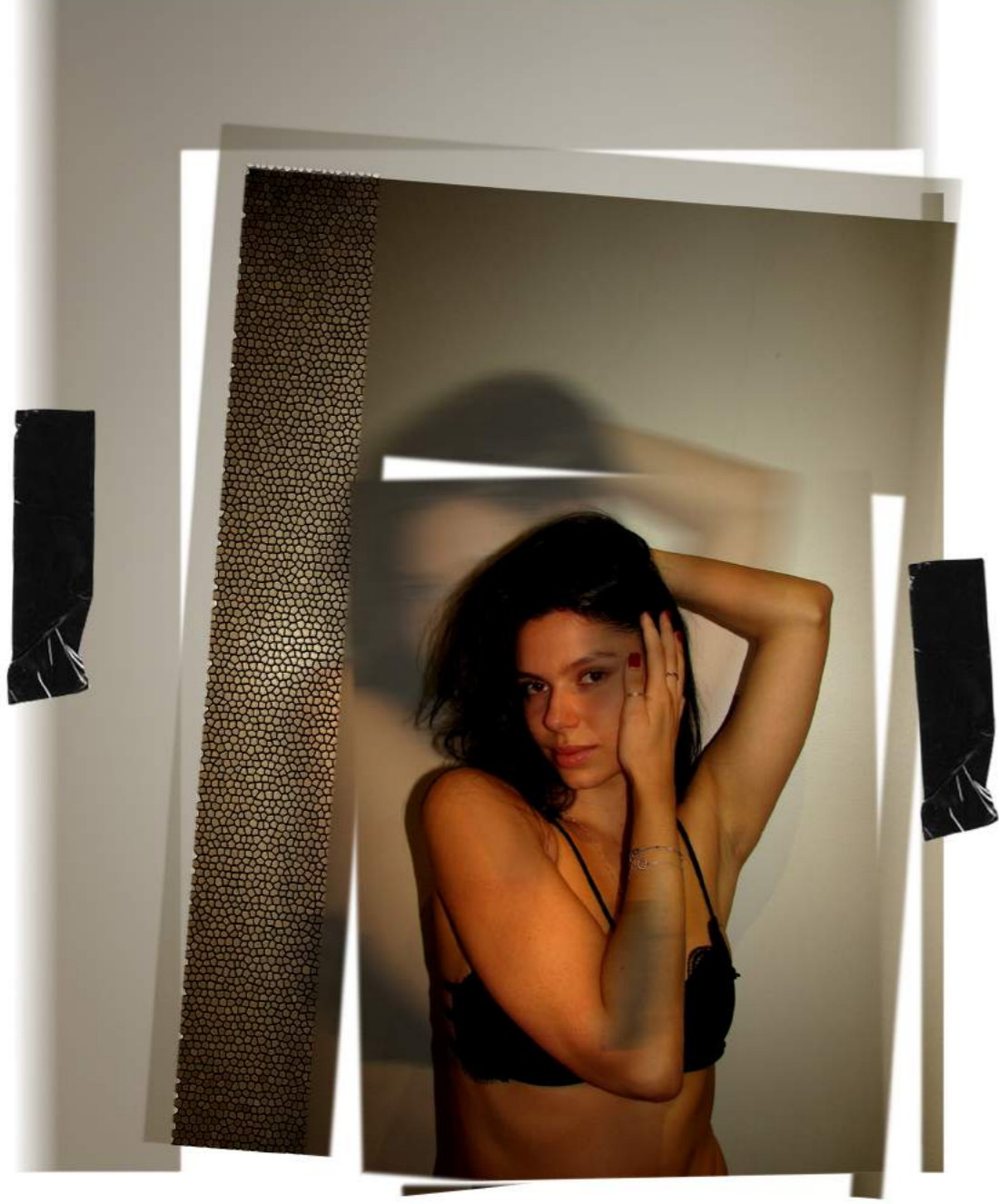

I LOVE you



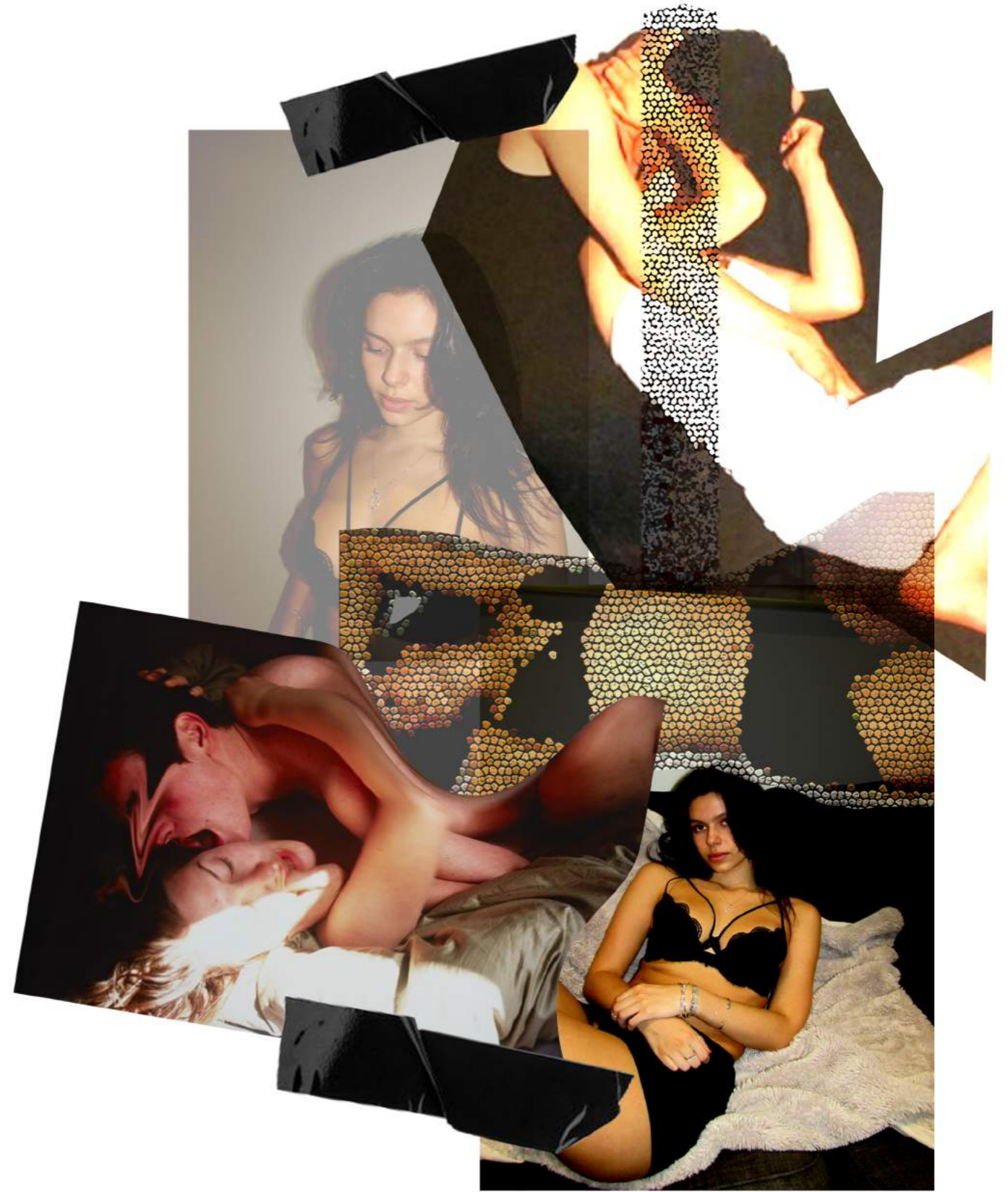

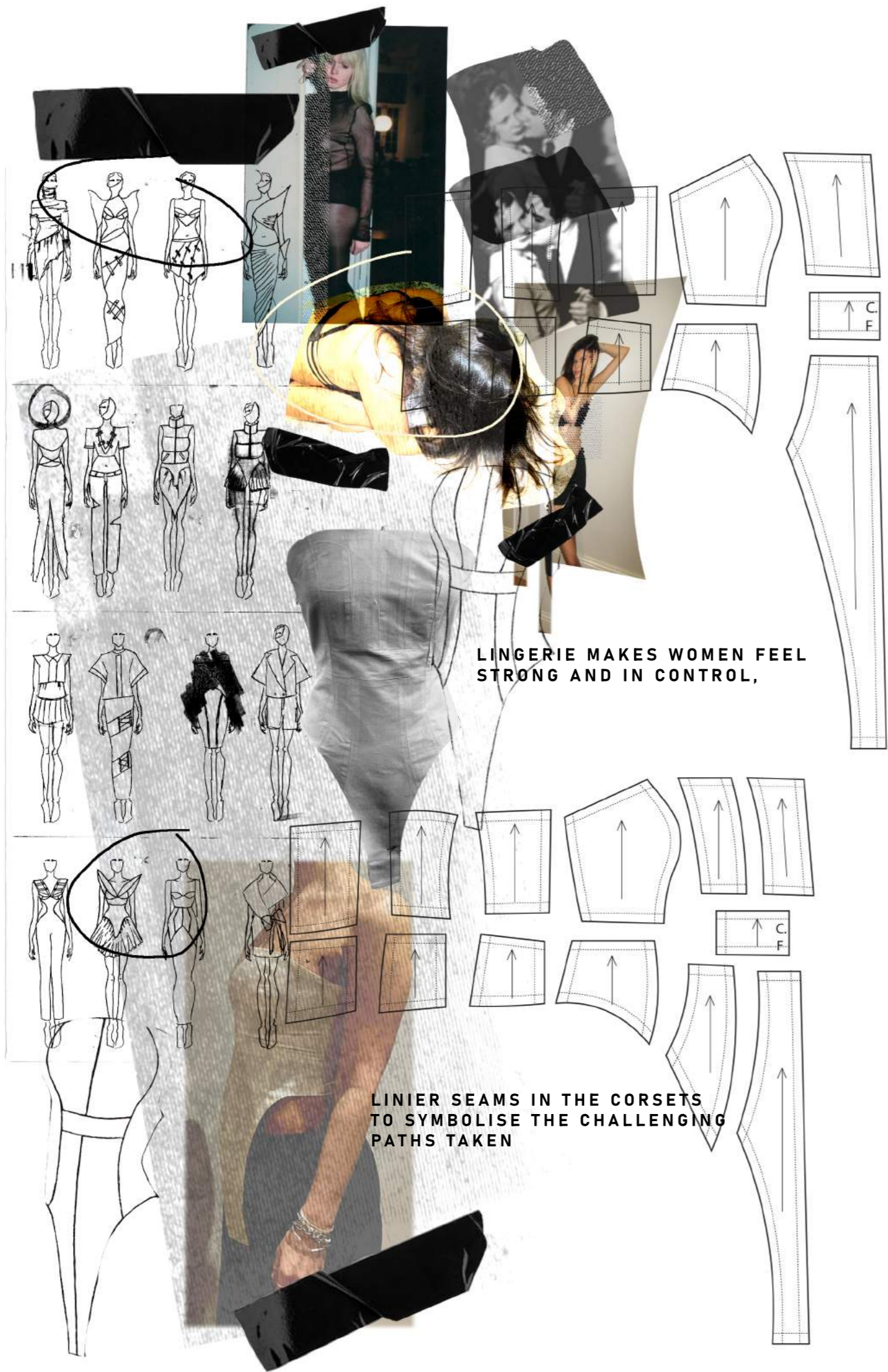

LINGERIE MAKES WOMEN FEEL STRONG AND IN CONTROL,

LINIER SEAMS IN THE CORSETS TO SYMBOLISE THE CHALLENGING PATHS TAKEN

**D
E
S
I
G
N
D
E
V
E
L
O
P
M
E
N
T**

CORSETS ARE A WAY OF EXUDING A POWERFUL FEMININE EXPRESSION ON THE OUTSIDE AND UNDERNEATH

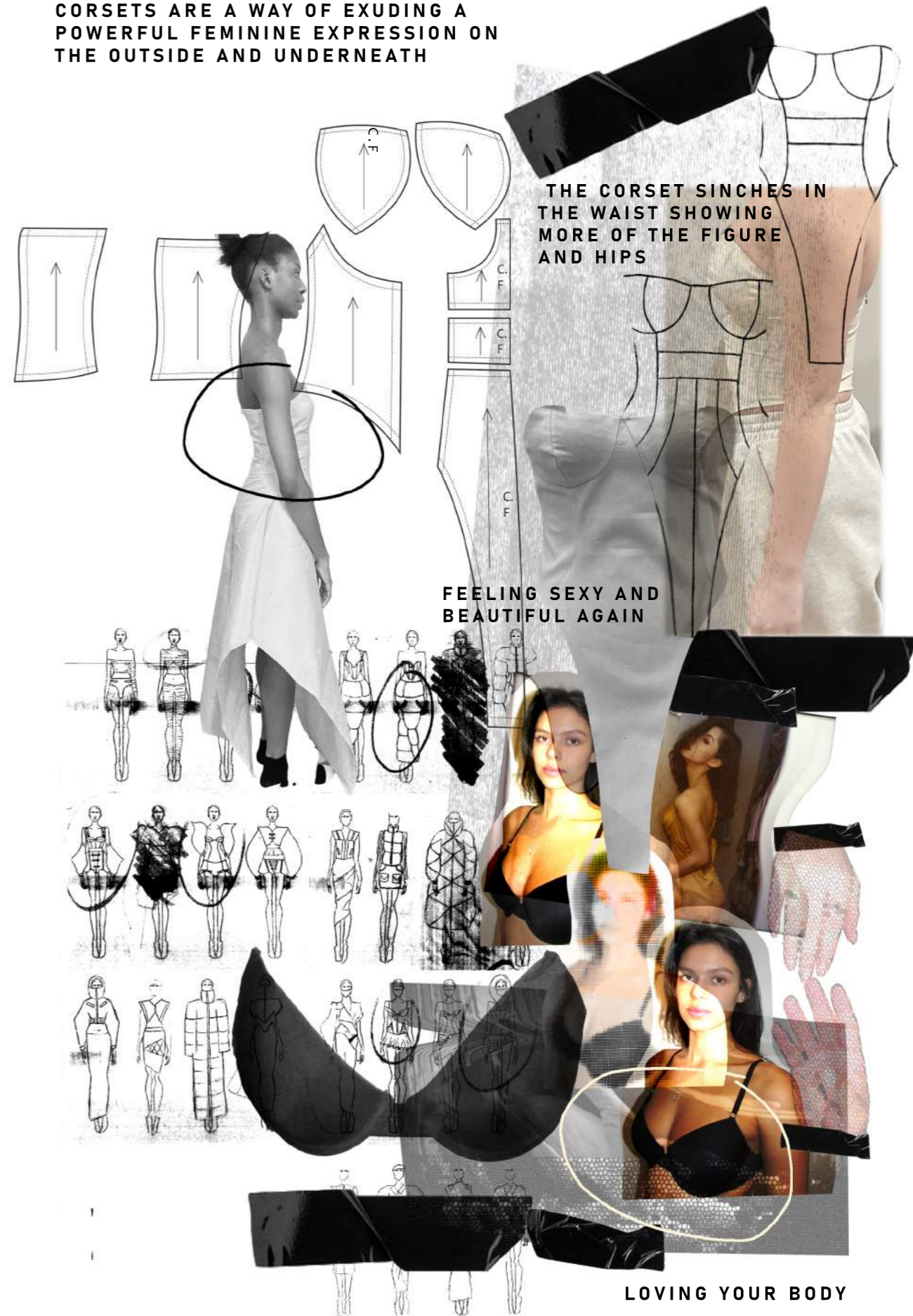

THE CORSET SINCHES IN THE WAIST SHOWING MORE OF THE FIGURE AND HIPS

FEELING SEXY AND BEAUTIFUL AGAIN

LOVING YOUR BODY

ALTERNATIVE DESIGNS OF USED STRUCTURE



**STRONG , BOLD , SHARP,
STRUCTURED- OVERCOMING THE
DIFFICULT CHALLENGES FACED**

ORIGINAL SKIRT DESIGNS

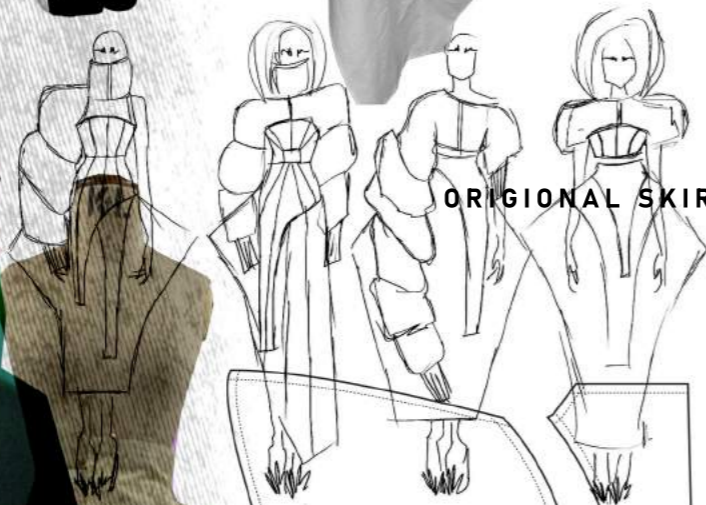

**SHARP POINTS, CUT x2
SYMBOLISING THE
COURAGE AND
STRENGTH TO FIGHT,
PHYSICALLY AND
MENTALLY**

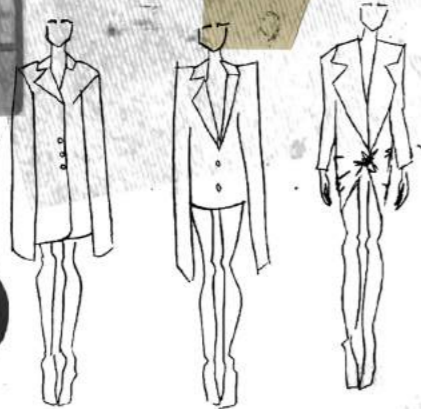

**CREATING VARIOUS LENGTHS IN THE
SKIRT TO SHOW MORE LEG,
SUGGESTING OPENNESS AND
ENGAGEMENT**

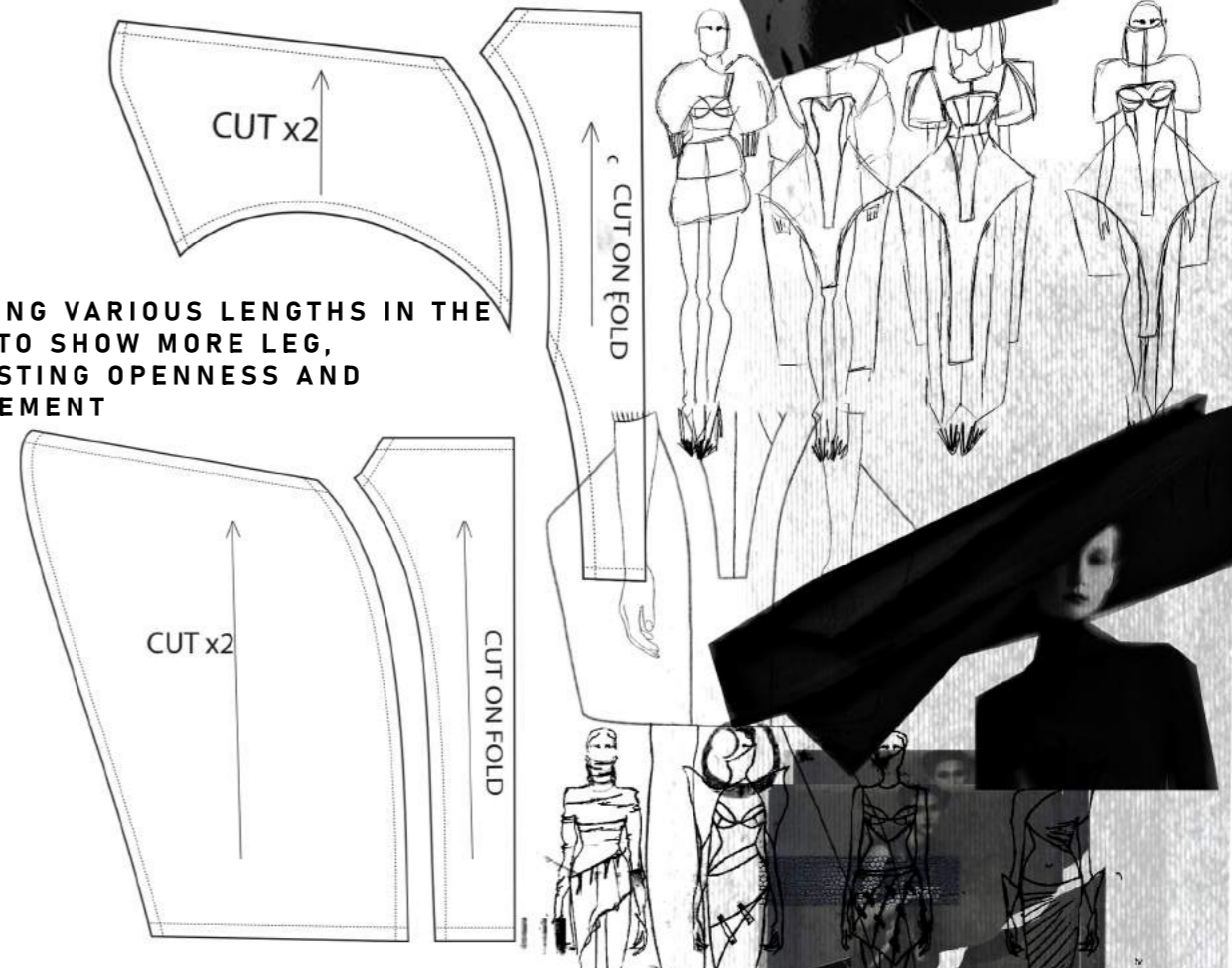

STRUCTURED





SKIRTS GIVES OFF A SENSE OF FLUIDITY AND COHESIVENESS, REPRESENTING CHANGE AND THE PASSAGE OF TIME

FORGETTING ABOUT THE PAST AND MOVING FORWARD

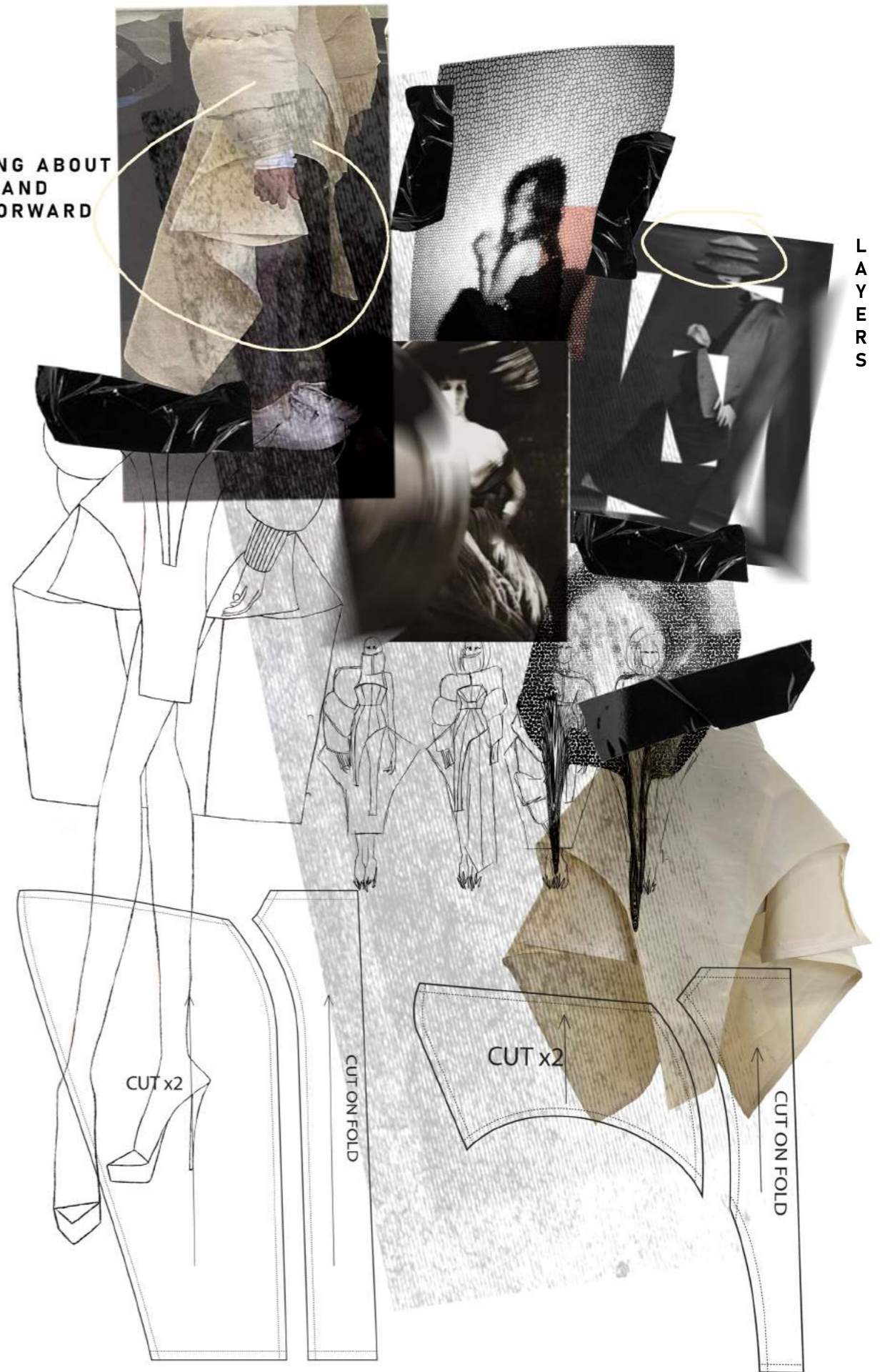

LAYERS

ORIGINAL PUFFER DESIGNS



HIDING BEHIND THE WALLS FROM REALITY

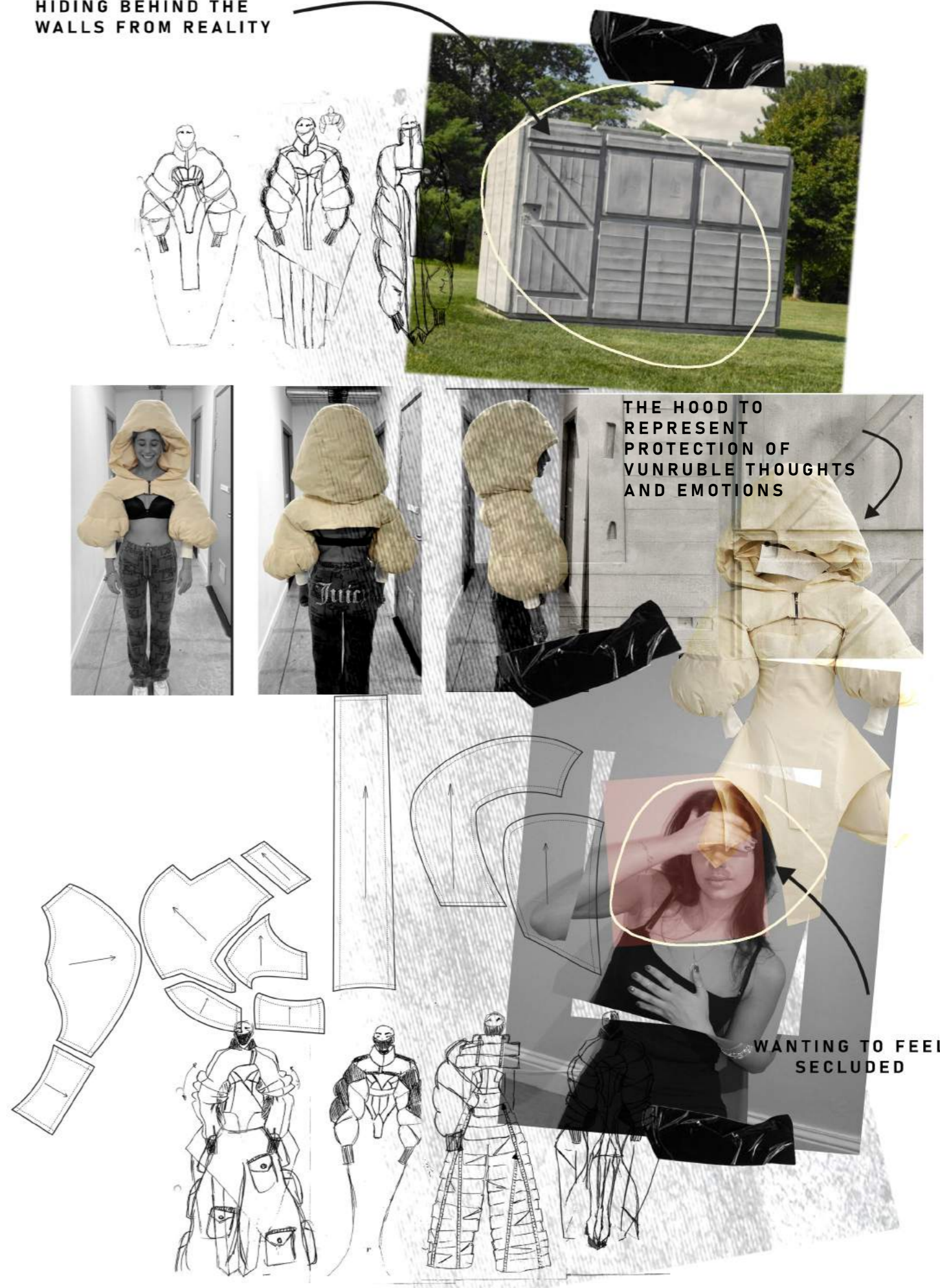

THE HOOD TO REPRESENT PROTECTION OF VUNRUBLE THOUGHTS AND EMOTIONS

CREATING CHUNKY SLEEVES TO FEEL EXTRA PROTECTED AND GUARDED

WANTING TO FEEL SECLUDED

TAKING INSPIRATION FROM THE LINE DETAILS TO REPRESENT THE SEAMS IN THE PUFFER JACKET

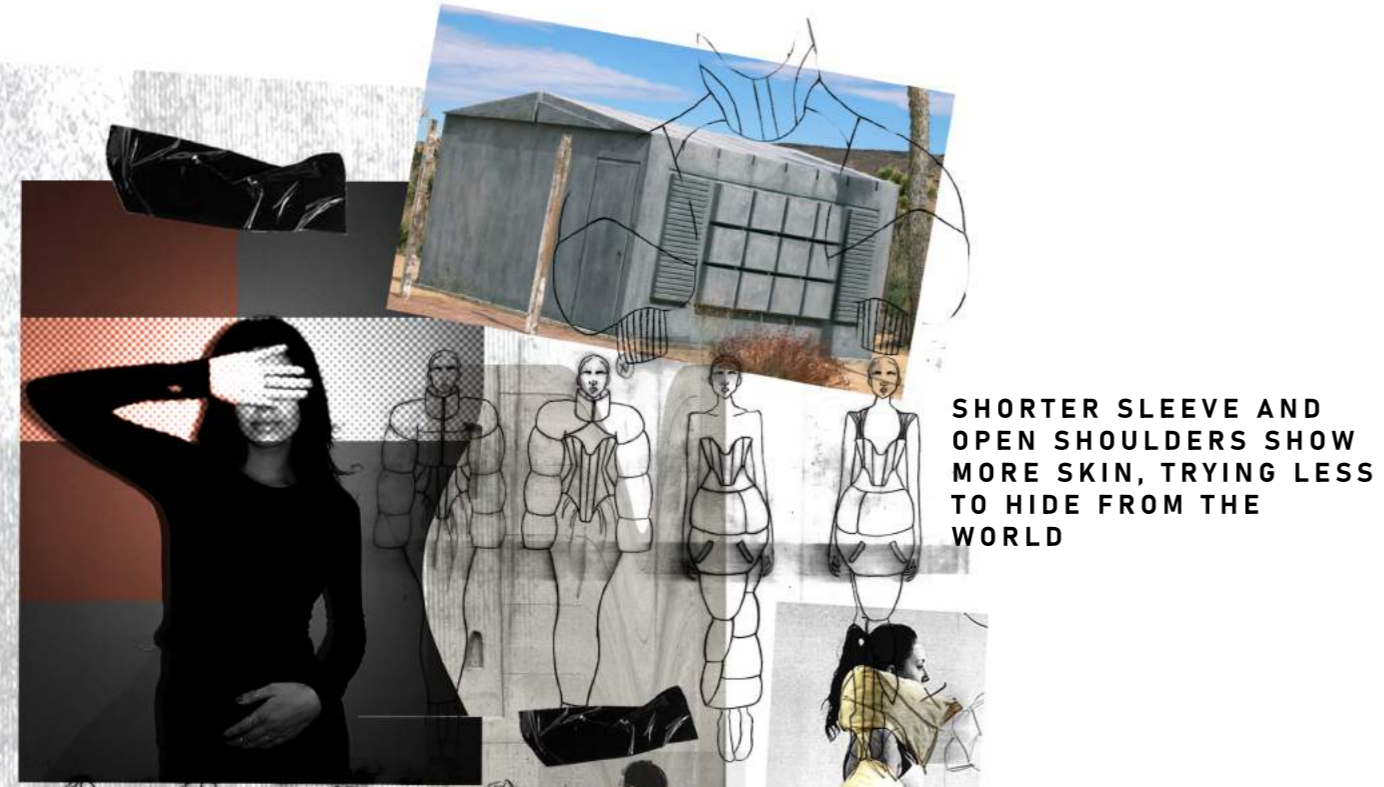

SHORTER SLEEVE AND OPEN SHOULDERS SHOW MORE SKIN, TRYING LESS TO HIDE FROM THE WORLD

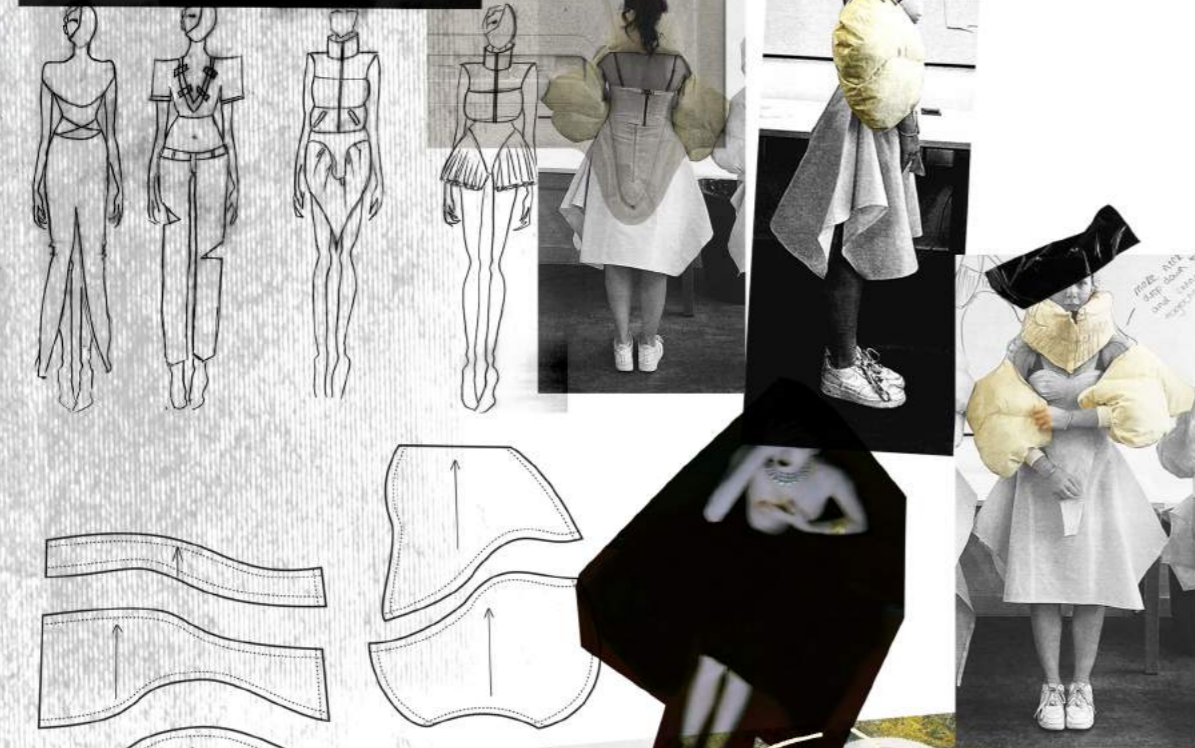

ADDING CURVATURE TO THE SLEEVE PATTERN SYMBOLISES THE UP AND DOWN EMOTIONS.

SEAM CHANNELS THROUGH PATTERN PIECE TO INTERPRET OVERTHINKING AND THE MIND GOING IN DIFFERENT DIRECTIONS

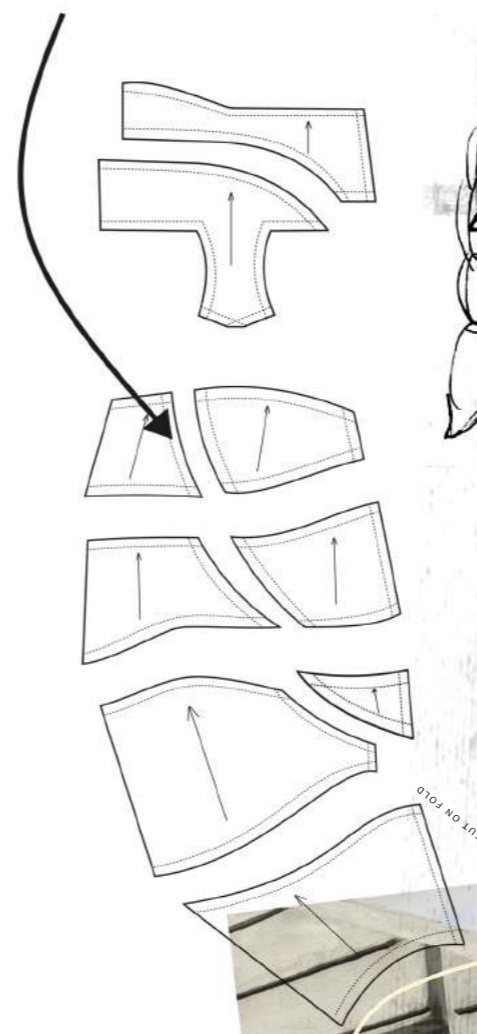

RE-CREATING THE BRICK PANEL DETAILS IN DIFFERENT PROPORTIONS ON THE SLEEVE

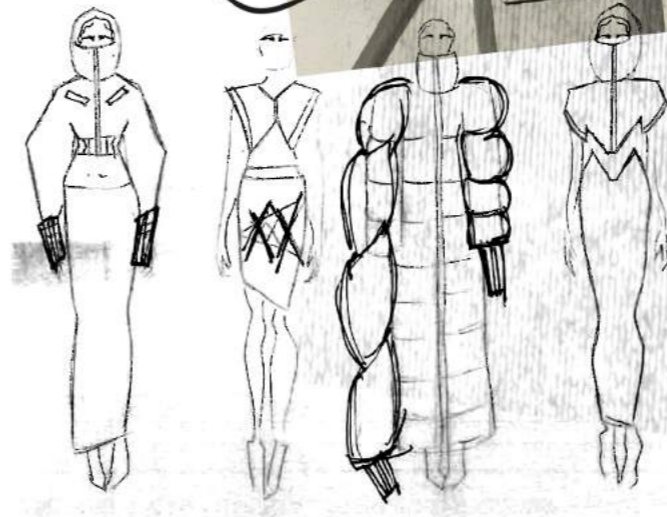

MIND SCATTERED

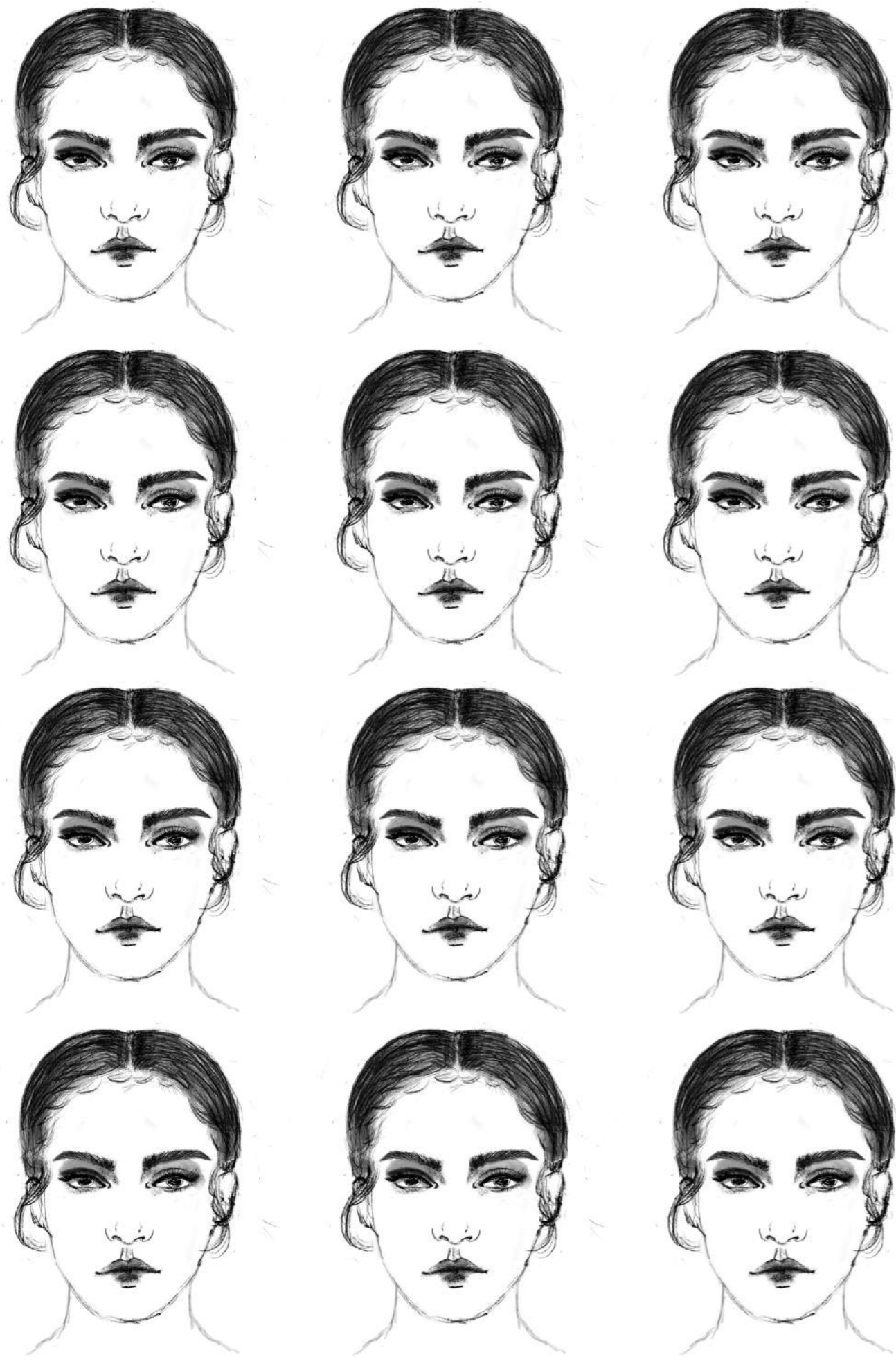

FINAL LINE UP



1.

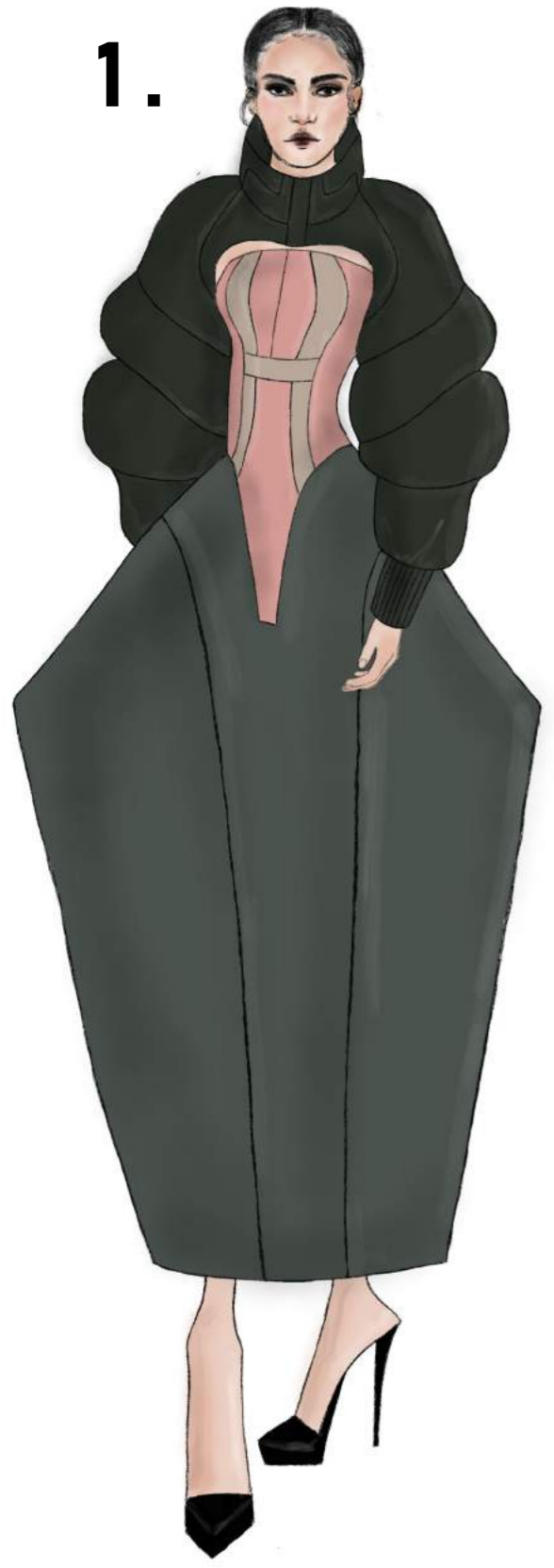

2.



3.

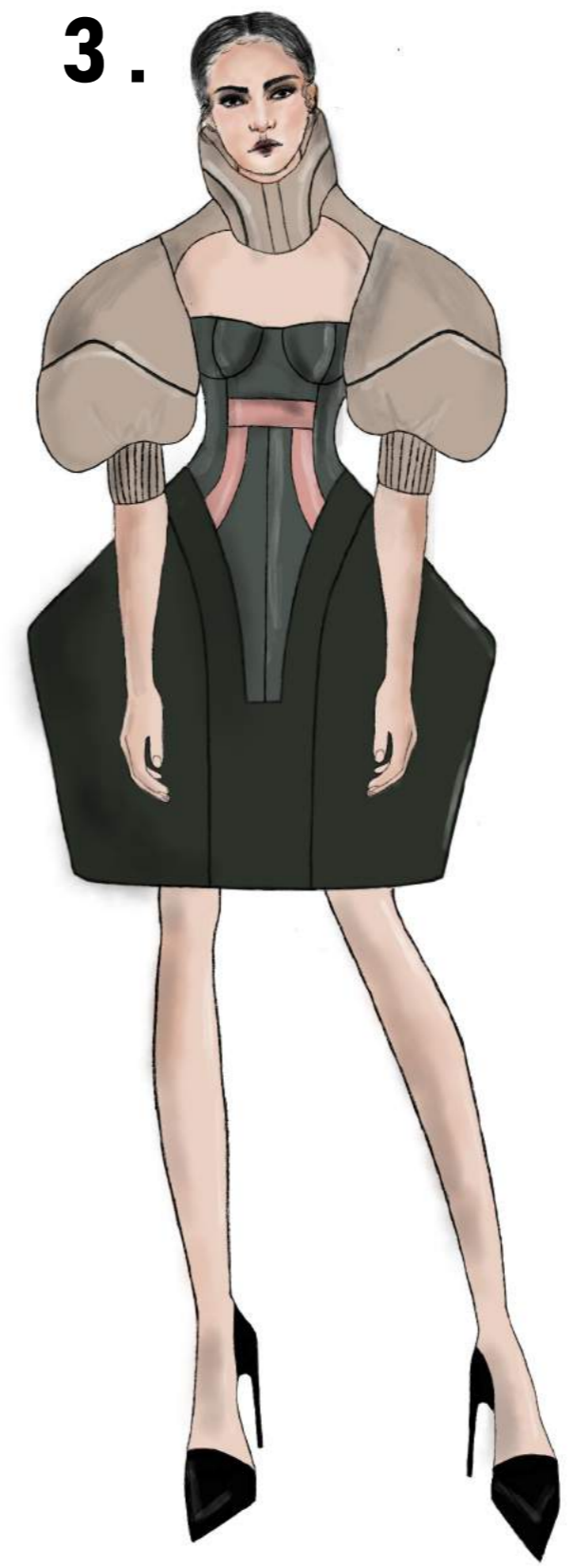

4.





FRONT

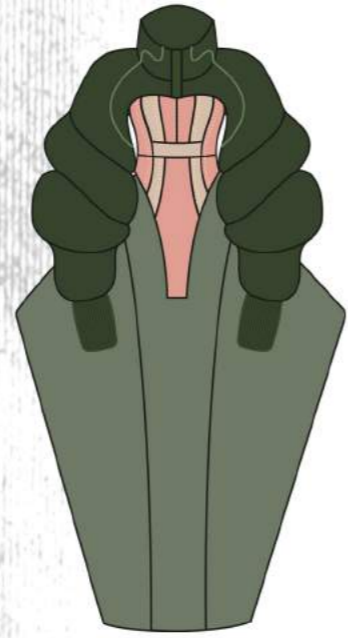

BACK



L
O
O
K
1

L
O
O
K
2

FRONT

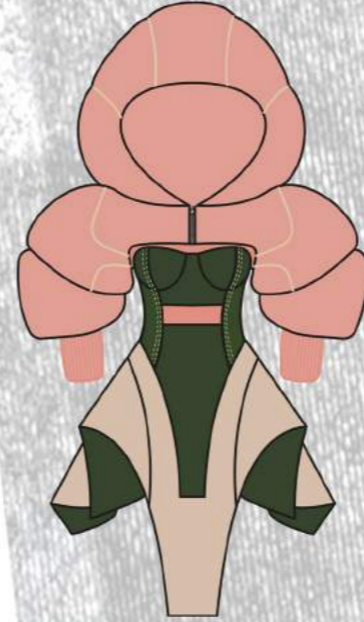

BACK

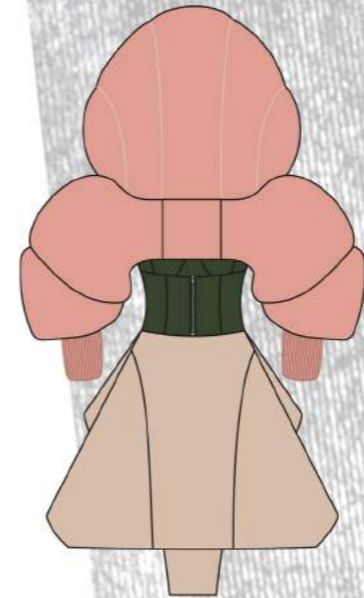

LOOK 3

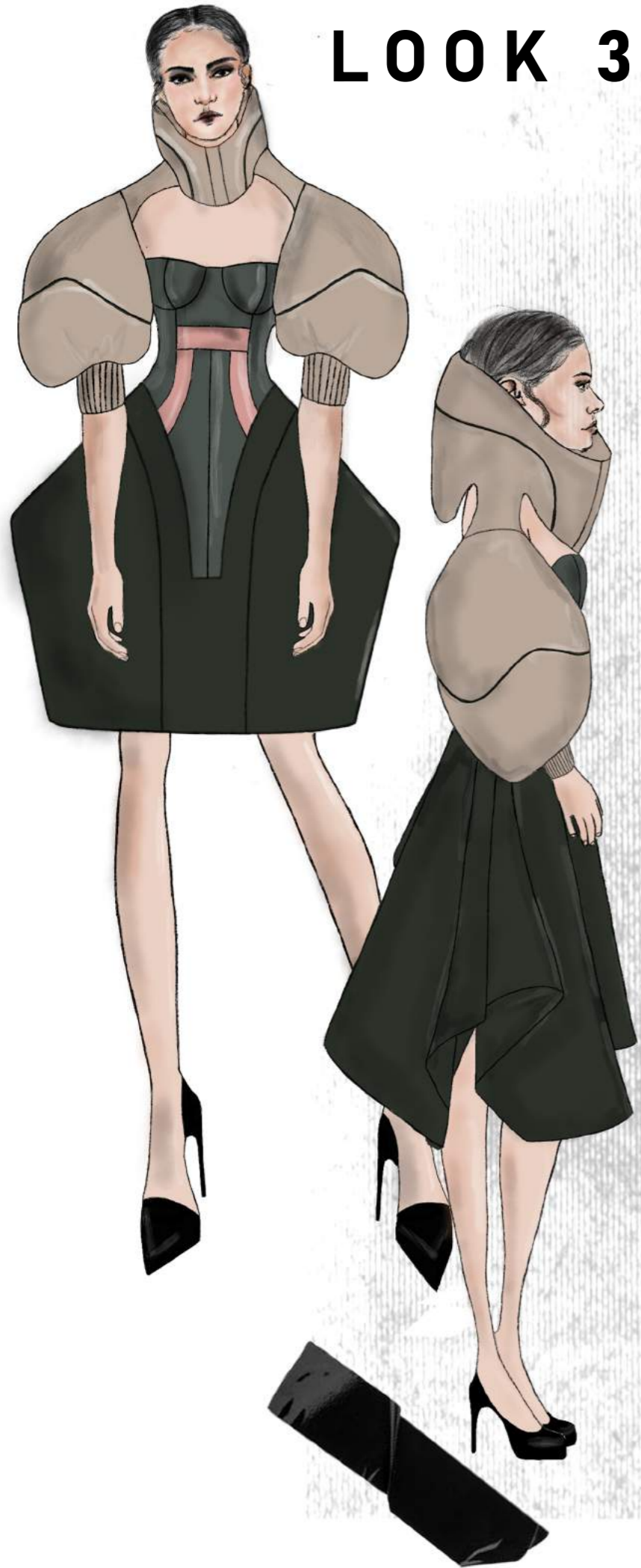

FRONT

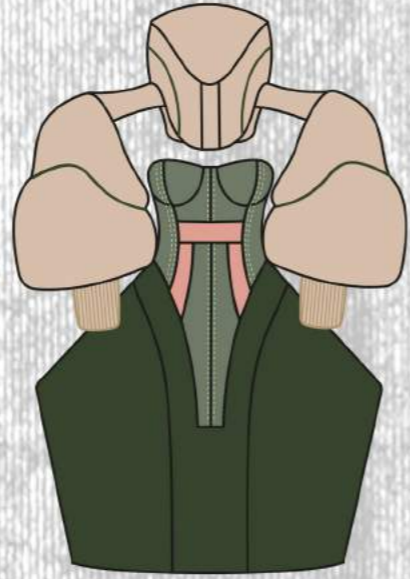

BACK

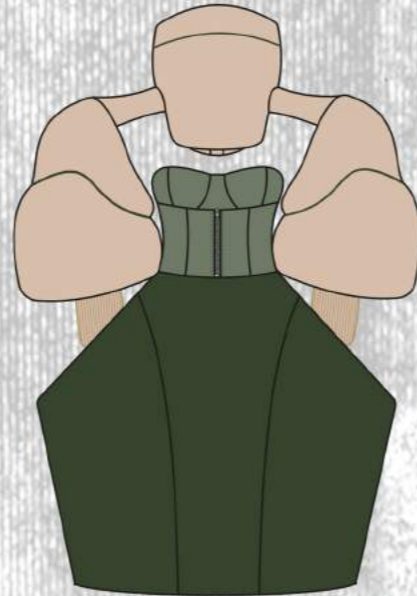

FRONT



BACK



LOOK 4

1

1A. CHUNKY PUFFER JACKET IN COATED COTTON UTILITY GREEN, WITH ANTIQUE BRASS ZIP IN DARK OLIVE AND BRASS PRESS STUD FASTENINGS

1B. FITTED CORSET IN PINK SABAKU TWILL AND BEIGE, WITH ECRU TOP STICH AND ECRU ANTIQUE BRASS ZIP

1C. FLOOR LENGTH SKIRT IN THE REAL MG WITH INVISIBLE ZIP IN DARK OLIVE.

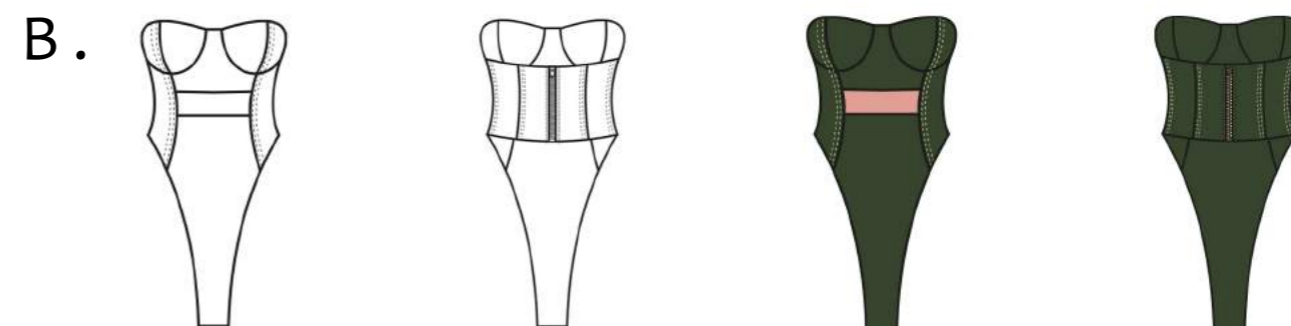
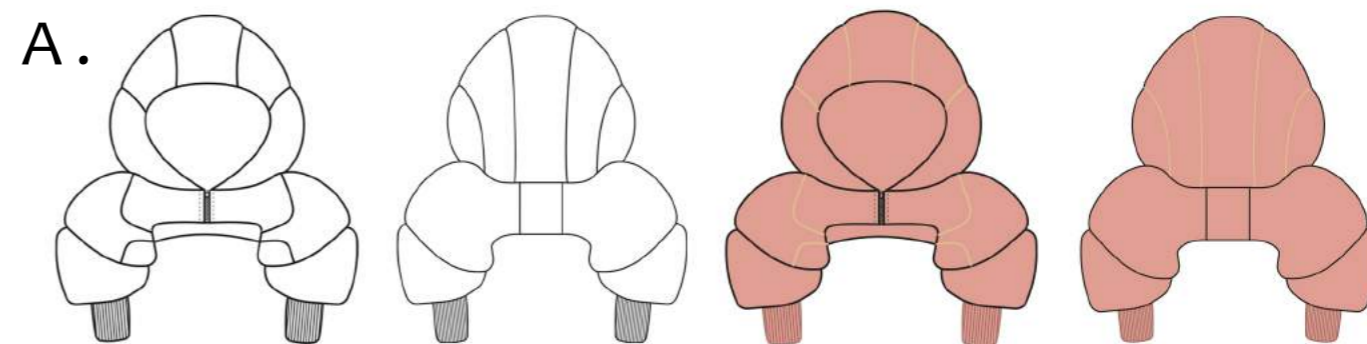
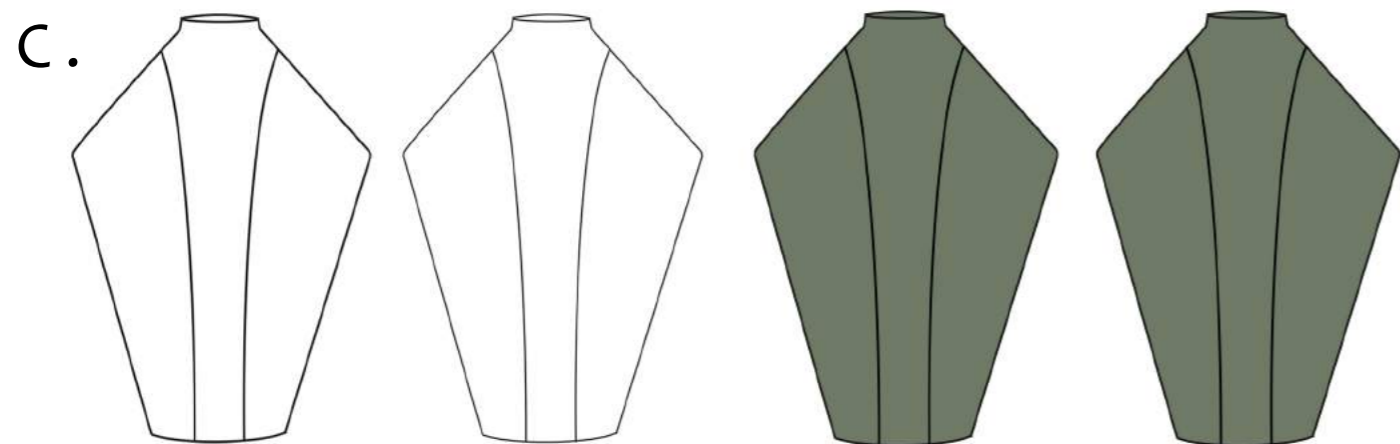
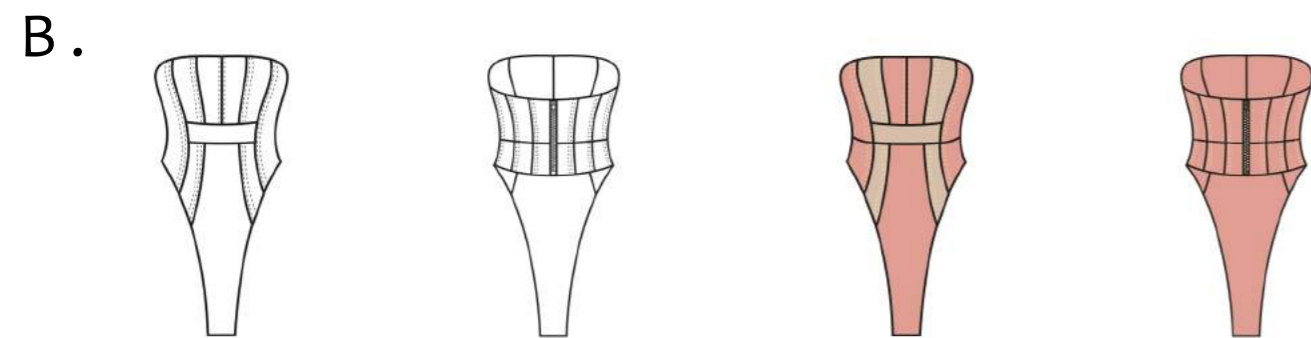
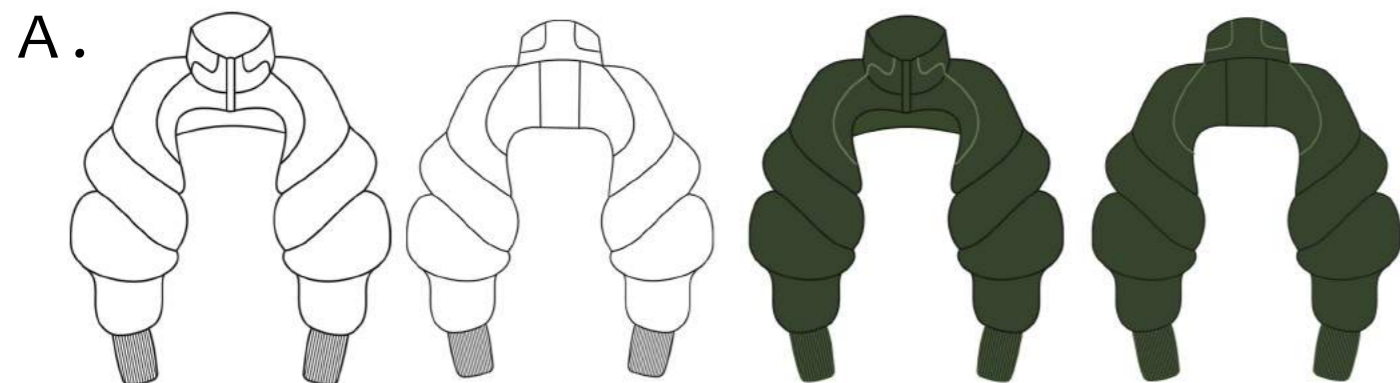

2

2A. CHUNKY THREE QUATER LENGTH SLEEVE PUFFER JACKET WITH HOOD IN PINK SABAKU TWILL AND ANTIQUE BRASS ZIP IN PINK PUFF

2B. FITTED CORSET IN COATED COTTON UTILITY GREEN AND PINK SABAKU TWILL WITH ECRU TOP STICH AND ECRU ANTIQUE BRASS ZIP

2C. SHORT SKIRT IN BEIGE WITH DARK OLIVE SATIN LINING AND INVISIBLE ZIP IN HAY

3

3A. CHUNKY THREE QUATER LENGTH SLEEVE WITH OPEN SHOULDER PUFFER JACKET IN BEIGE WITH ANTIQUE BRASS ZIP IN BEIGE AND BRASS PRESS STUDS FASTENING

3B. FITTED CORSET IN THE REAL MG AND PINK SABAKU TWILL WITH ECRU TOP STICH AND ANTIQUE BRASS ZIP IN ECRU

3C. KNEE LENGTH SKIRT IN COATED COTTON UTILITY GREEN WITH INVISIBLE ZIP IN DARK OLIVE.

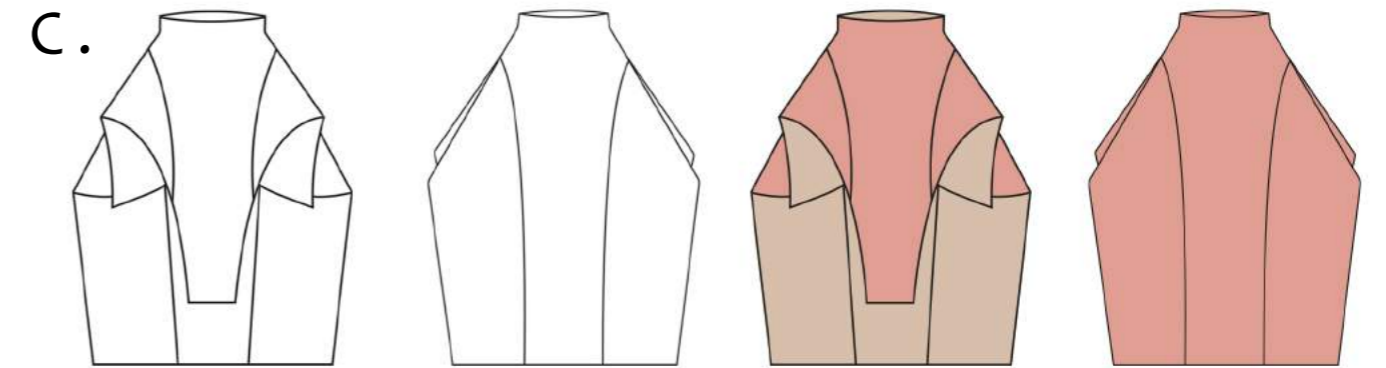
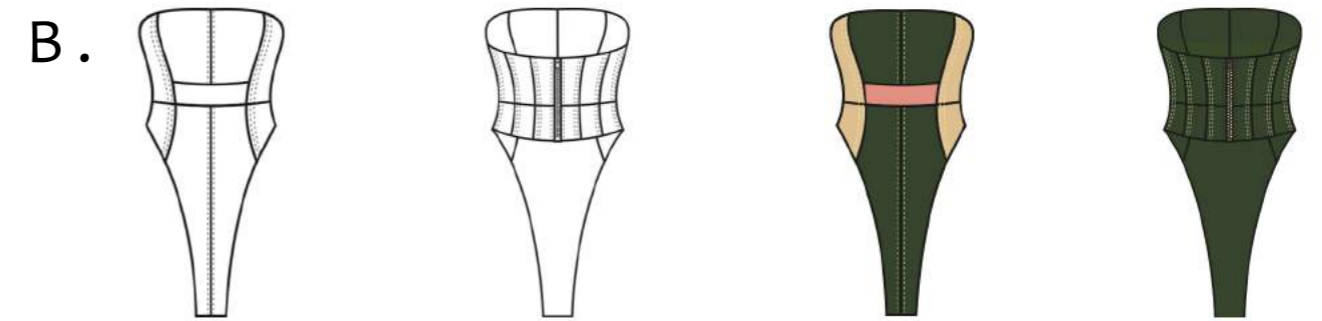
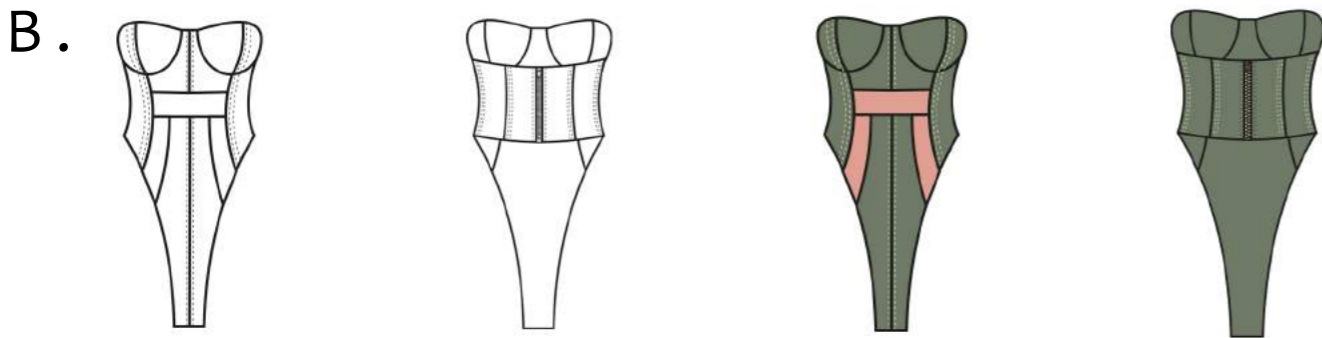
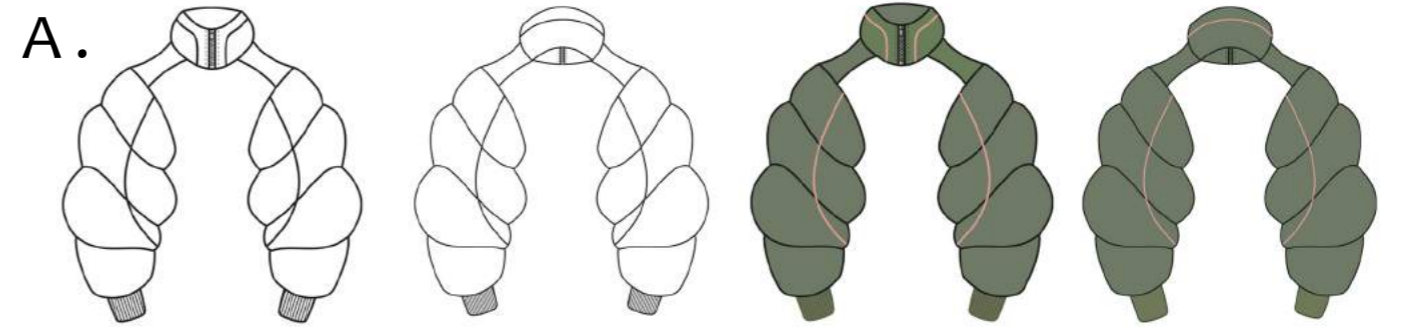
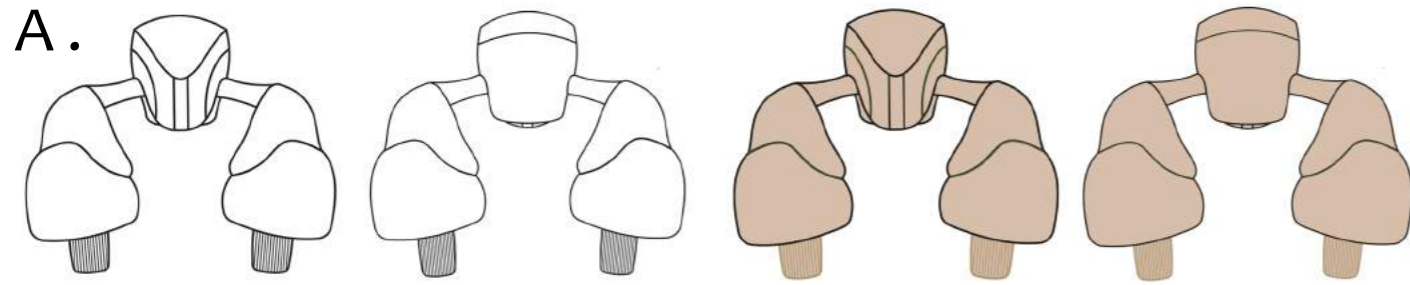

4

4A. CHUNKY LONG SLEEVE WITH OPEN SHOULDERS PUFFER JACKET WITH ANTIQUE BRASS ZIP IN DARK OLIVE

4B. FITTED CORSET IN COATED COTTON UTILITY GREEN, PINK SABAKU TWILL AND BEIGE WITH ECRU TOP STICH AND ANTIQUE BRASS ZIP IN ECRU

4C. MIDI SKIRT IN PINK SABUKU TWILL WITH BEIGE LINING AND INVISIBLE ZIP IN PETAL PINK

WITH PUFFER JACKET



L
O
O
K



1

WITHOUT PUFFER JACKET



LOOK

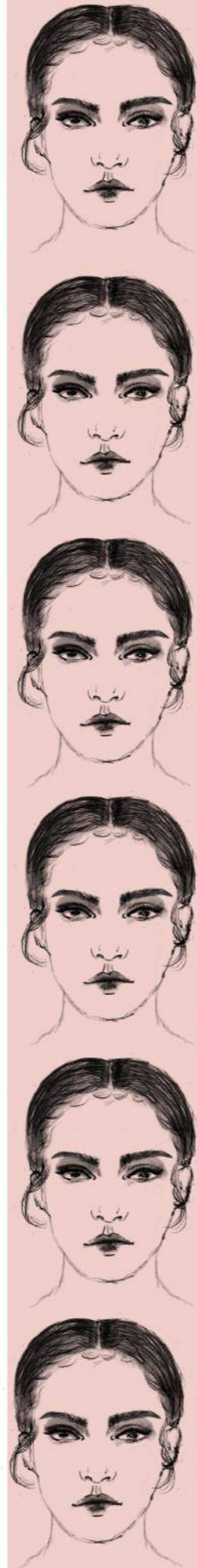

2



WITH PUFFER JACKET



LOOK



3

WITHOUT PUFFER JACKET

WITH PUFFER JACKET



LOOK



4

WITHOUT PUFFER JACKET

